



1.

—

2.

3.

—

4. *

5.



(
)

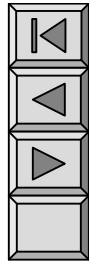

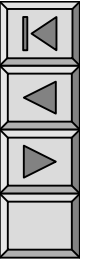

§ 13-1

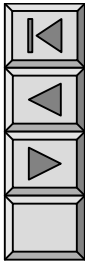

1.

2.

()

$f(t)$

$$f(t) = f(t+kT)$$



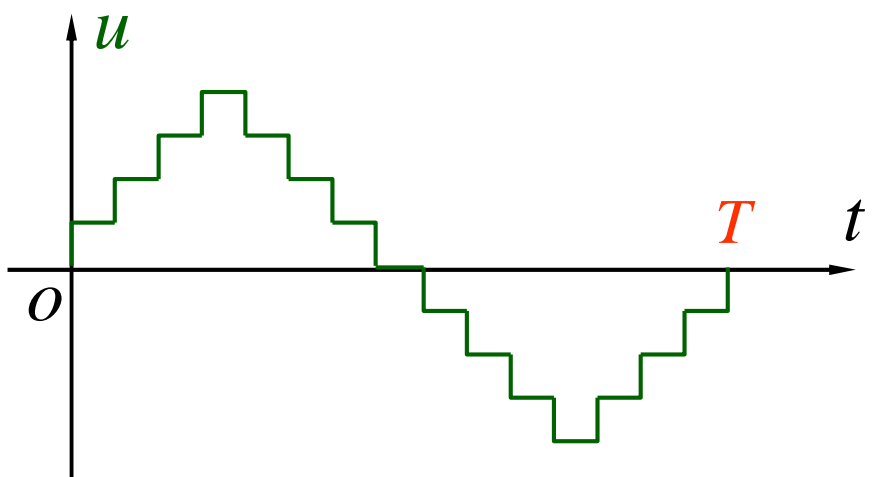
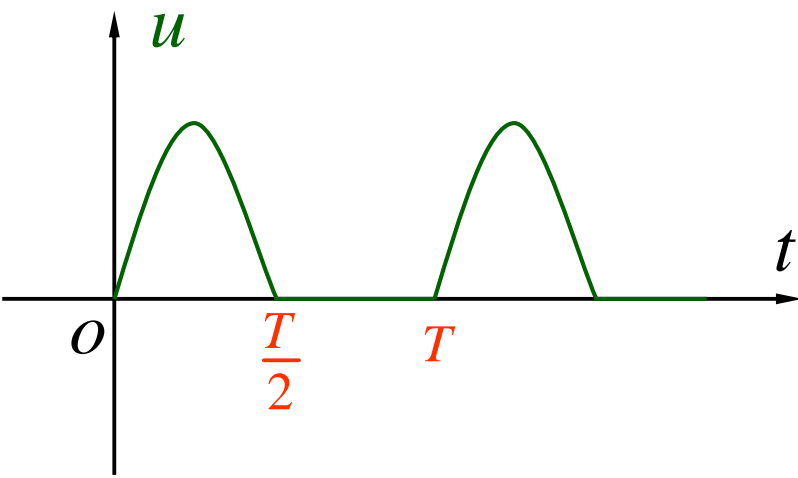
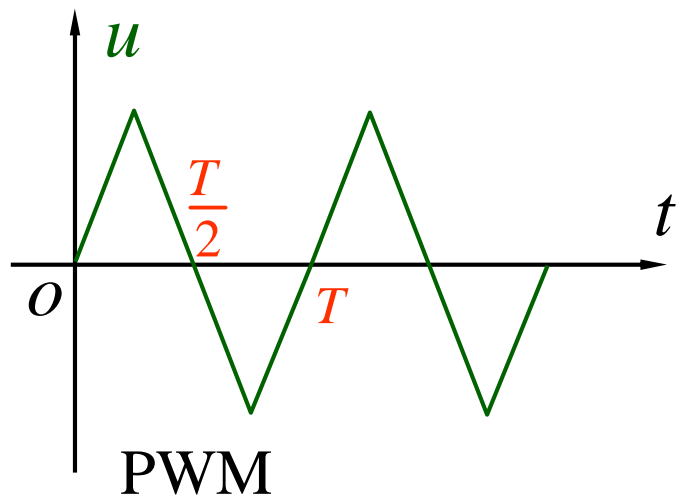
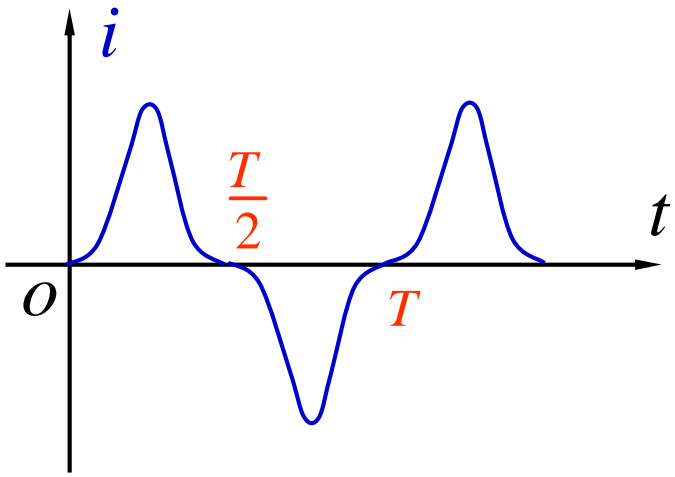

§ 13-2

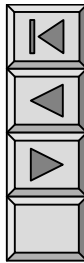

1.

$f(t)$

“ ”

$$f(t) = a_0 + \sum_{k=1}^{\infty} [a_k \cos(k\omega_1 t) + b_k \sin(k\omega_1 t)]$$

$$a_0 = a_k = b_k = \frac{1}{T} \int_0^T f(t) dt$$

$$a_k = \frac{2}{T} \int_0^T f(t) \cos(k\omega_1 t) dt \quad b_k = \frac{2}{T} \int_0^T f(t) \sin(k\omega_1 t) dt$$



$$a_0 = \frac{1}{T} \int_0^T f(t) dt$$

$$a_k = \frac{2}{T} \int_0^T f(t) \cos(k \omega_1 t) dt$$

$$b_k = \frac{2}{T} \int_0^T f(t) \sin(k \omega_1 t) dt$$

[0

$$a_k = \frac{1}{T} \int_0^T f(t) \cos(k \omega_1 t) d(\omega_1 t)$$

$$a_k = \frac{1}{T} \int_0^T f(t) \cos(k \omega_1 t) d(\omega_1 t)$$

$$a_0 \quad b_k$$



$$f(t) = a_0 + \sum_{k=1}^{\infty} [a_k \cos(k t) + b_k \sin(k t)]$$

$$\frac{a_k \quad b_k}{\quad}$$

$$a_k = A_{km} \cos \quad b_k = A_{km} \sin$$

$$f(t) = A_0 + \sum_{k=1}^{\infty} A_{km} \cos(k t - \phi_k)$$

$$A_{km} = \sqrt{a_k^2 + b_k^2} \quad \phi_k = \arctg \frac{b_k}{a_k}$$

$$f(t) = A_0 + \sum_{k=1}^{\infty} A_{km} \cos(k\omega_1 t + \varphi_k)$$

$$A_0 = \frac{1}{T} \int_0^T f(t) dt$$

$$A_{km} = \frac{2}{T} \int_0^T f(t) \cos(k\omega_1 t) dt$$

$$\varphi_k = \arctg \frac{b_k}{a_k}$$

$$a_k = \frac{1}{T} \int_0^T f(t) \cos(k\omega_1 t) dt$$

$$A_{km} = \sqrt{a_k^2 + b_k^2}$$

$$\varphi_k = \arctg \frac{b_k}{a_k}$$

$$k = 2$$

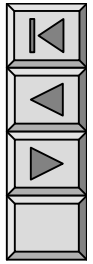



$$f(t) = A_0 + \sum_{k=1}^{\infty} A_{km} \cos(k\omega_1 t + \phi_k)$$

2.

$f(t)$

$f(t)$

$$f(t) = \sum_{k=1}^{\infty} A_{km} \cos(k\omega_1 t + \phi_k)$$

k

k

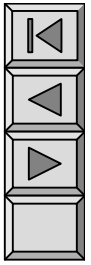



3.

(1) $f(t)$ “ ”

$$f(t) = f(t \pm T/2)$$

$$a_{2k} = b_{2k} = 0$$

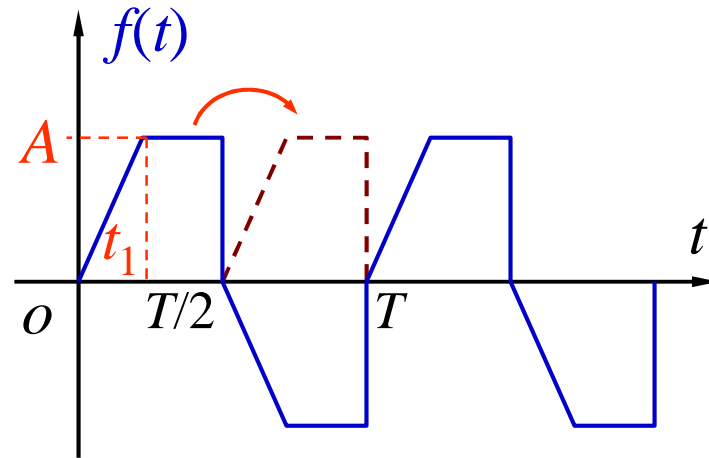

$f(t)$ “ ”

$$A_0 = \frac{1}{T} \int_0^T f(t) dt$$

$$A_0 = 0$$

$$A_0 = \int f(t)$$

$$f(t) = A_0$$



(2) $f(t)$

$$f(t) = f(t)$$

$$b_k = 0$$

$$A_0 = \frac{2}{T} \int_0^{\frac{T}{2}} f(t) dt$$

$$a_k = \frac{4}{T} \int_0^{\frac{T}{2}} f(t) \cos(k_1 t) dt$$

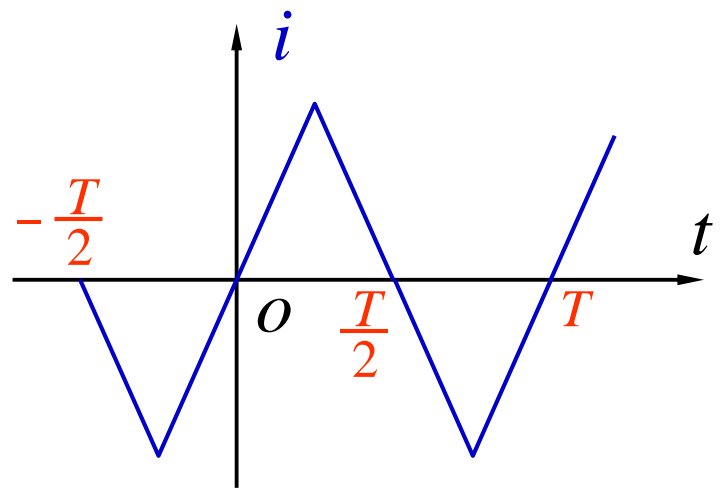
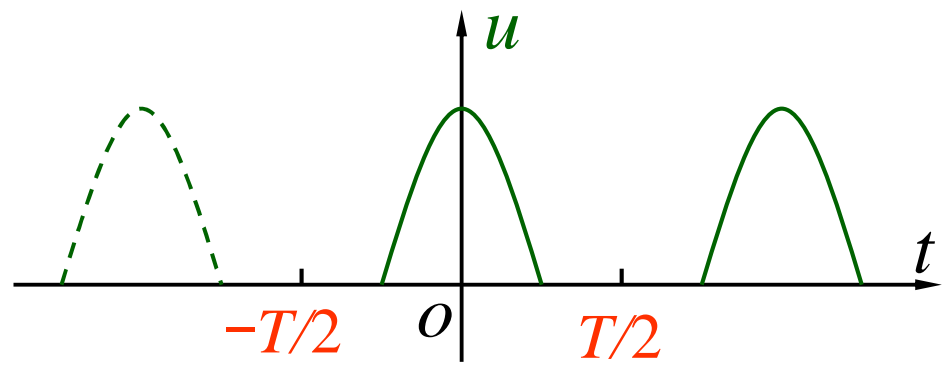

(3) $f(t)$

$$f(t) = f(t)$$

$$a_k = 0$$

$$b_k$$

$$b_k = \frac{4}{T} \int_0^{\frac{T}{2}} f(t) \sin(k_1 t) dt$$



(4) $f(t)$

$$f(t) = f(t \pm T/2)$$

$$a_{2k+1} = b_{2k+1} = 0$$

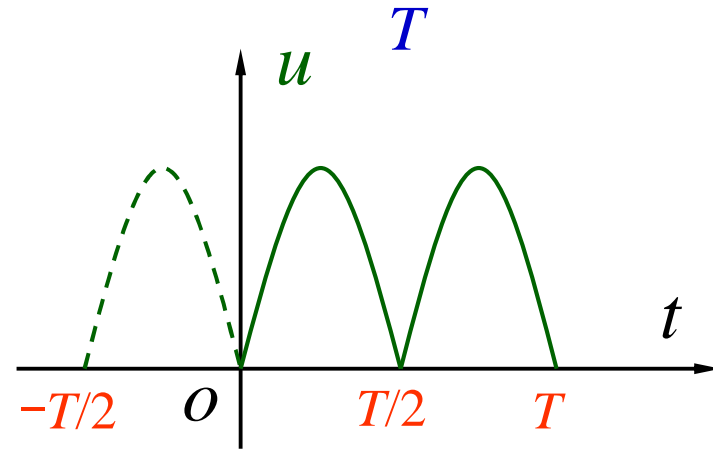

$f(t)$

()

A_{km}

a_k b_k

k

1

$f(t)$

$a_k = 0$

$$b_k = \frac{2}{T} \int_0^T E_m \sin(k \omega_1 t) dt$$

$$= \frac{2E_m}{k} [1 - \cos(k \pi)]$$

$$\begin{cases} 0 & k \text{ even} \\ \frac{4E_m}{k} & k \text{ odd} \end{cases}$$

P320

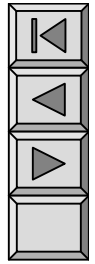
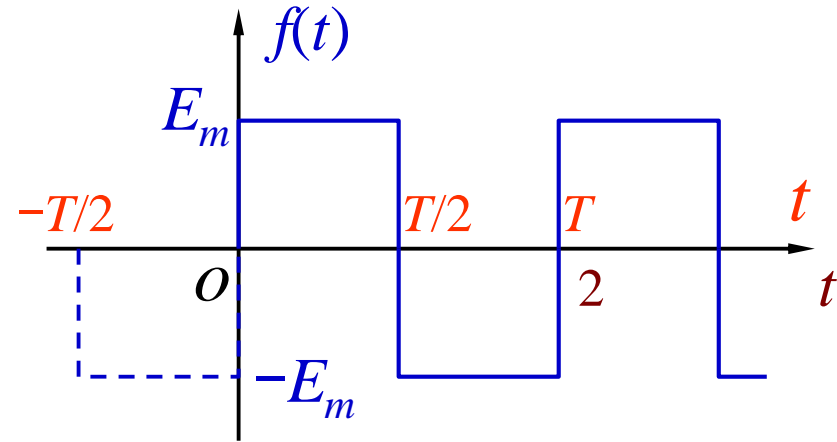

$T/4$

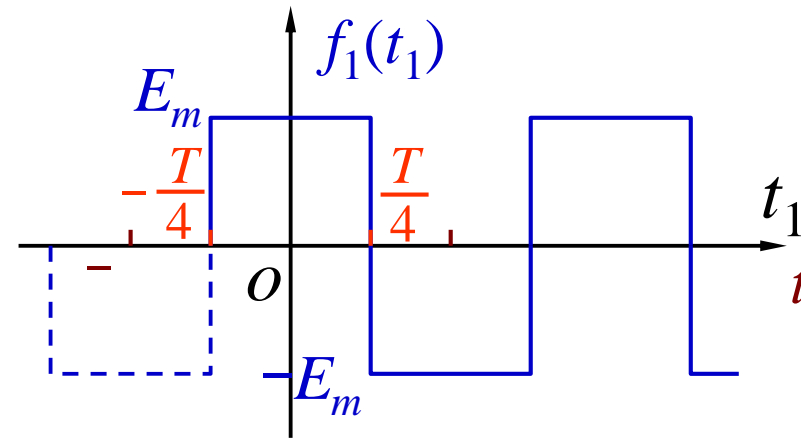

$$f(t) = f_1\left(t - \frac{T}{4}\right) = f_1(t_1)$$

$$A_0 = 0 \quad b_k = 0$$

$$a_k = \frac{2}{T} \int_0^T E_m \cos(k \omega_1 t_1) dt_1$$

$$= \frac{2}{T} \left[\frac{E_m}{k} \sin(k \omega_1 t_1) \right]_0^T$$

$$= \frac{4E_m}{k} \sin \frac{k\omega_1 T}{2}$$

$$a_k = \frac{4E_m}{k} \sin \frac{k\pi}{2}$$

$$f_1(t_1) = \frac{4E_m}{\pi} \left[\cos(\omega_1 t_1) - \frac{1}{3} \cos(3\omega_1 t_1) + \frac{1}{5} \cos(5\omega_1 t_1) - \dots \right]$$

$$f_1(t_1) = \frac{4E_m}{\pi} \sum_{k=1}^{\infty} \frac{1}{2k-1} \cos[(2k-1)\omega_1 t_1]$$

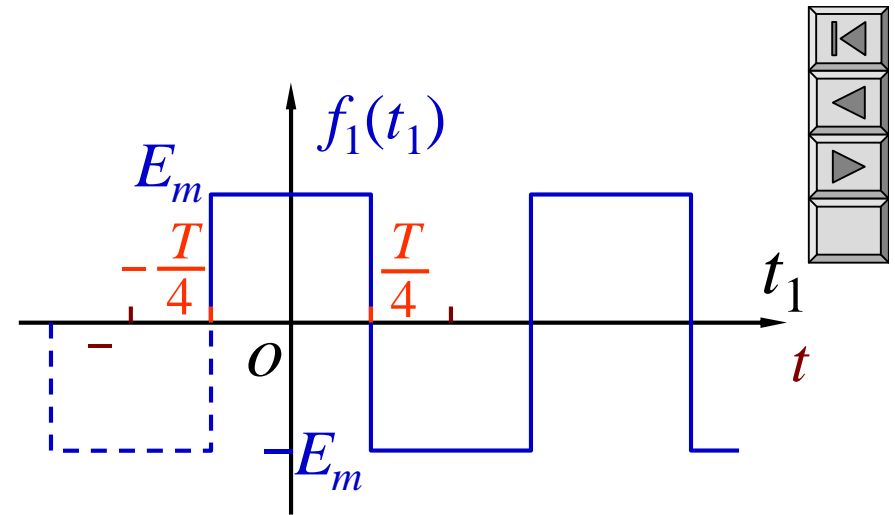



$$f(t) = f_1 \left[t - \frac{T}{4} \right]$$

$$f(t) = \frac{4E_m}{1T} \left[\cos \left(2\pi t - \frac{1T}{4} \right) + \frac{1}{3} \cos \left(3 \cdot 2\pi t - \frac{1T}{4} \right) + \dots \right]$$

$$f(t) = \frac{4E_m}{1T} \left[\sin \left(2\pi t \right) + \frac{1}{3} \sin \left(3 \cdot 2\pi t \right) + \frac{1}{5} \sin \left(5 \cdot 2\pi t \right) + \dots \right]$$

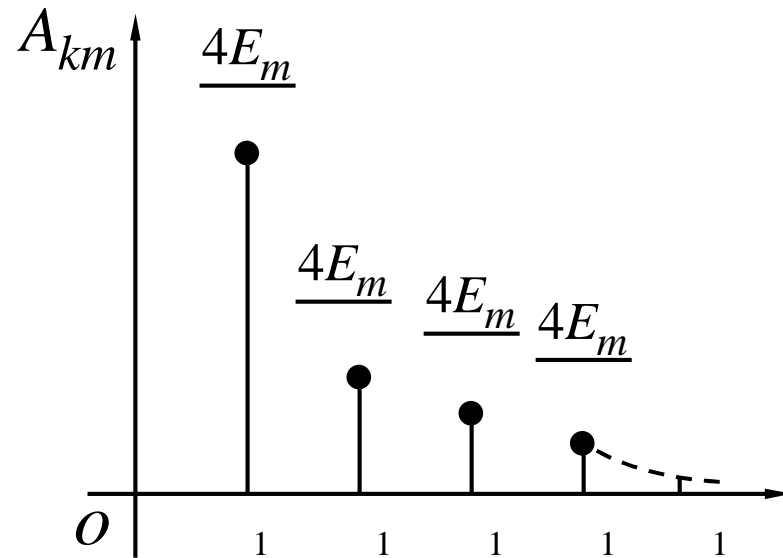

$$f(t) = \frac{4E_m}{\pi} \left[\sin(\omega_1 t) + \frac{1}{3} \sin(3\omega_1 t) + \frac{1}{5} \sin(5\omega_1 t) + \dots \right]$$

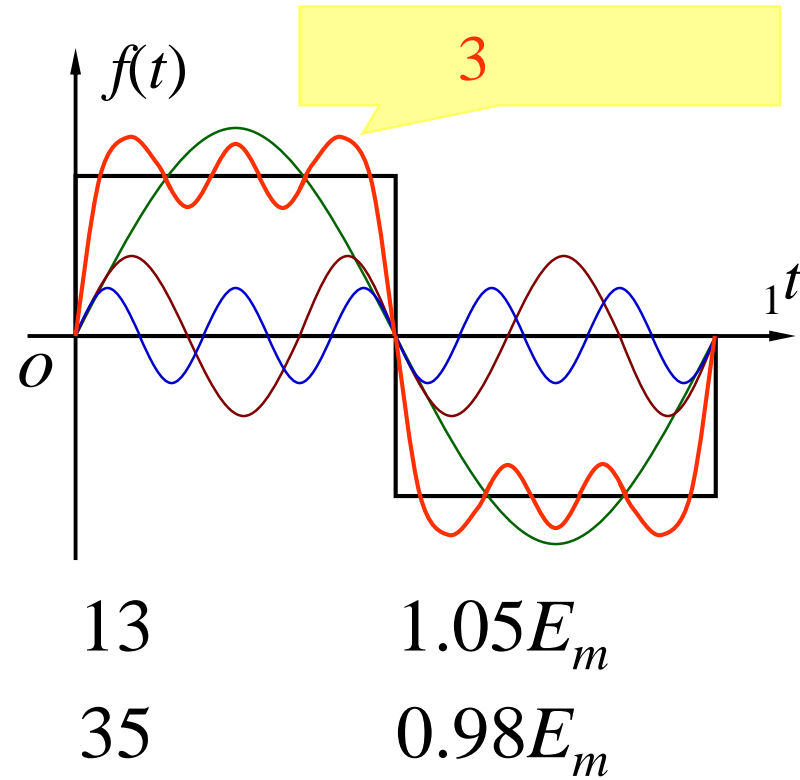
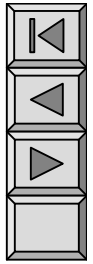

13

$1.05E_m$

35

$0.98E_m$

$$f\left(\frac{\pi}{2}\right) = 0.95E_m \quad ()$$

§ 13-3

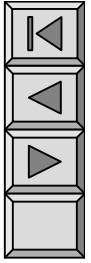

1.

$$I = \sqrt{\frac{1}{T} \int_0^T i^2(t) dt} \quad \text{有效值}$$

()

$\tilde{n} \sin \cos \sin^2 \cos^2$ "yo &



$$i = I_0 + \sum_{k=1}^{\infty} I_{km} \cos(k \omega_1 t - \phi_k)$$

$$i^2 = I_0^2 + 2I_0 \sum_{k=1}^{\infty} \underline{I_{km} \cos(k \omega_1 t - \phi_k)} + \sum_{k=1}^{\infty} \sum_{q=1}^{\infty} \underline{I_{km} \cos(k \omega_1 t - \phi_k)} \underline{I_{qm} \cos(q \omega_1 t - \phi_q)}$$

$$\sum_{k=1}^{\infty} \underline{I_{km}^2 \cos^2(k \omega_1 t - \phi_k)} + \sum_{k=1}^{\infty} \underline{2I_{km} \cos(k \omega_1 t - \phi_k) I_{qm} \cos(q \omega_1 t - \phi_q)}$$

\downarrow
 $2\cos^2$ \downarrow
 $1 + \cos 2$

$$\sum_{k=1}^{\infty} I_k^2$$

$$\frac{1}{T} \int_0^T I_0^2 dt = I_0^2$$



$$I = \sqrt{I_0^2 + I_1^2 + \dots + I_k^2} = \sqrt{I^2 + I^2 + I^2 + I^2 + \dots}$$

$$U = \sqrt{U_0^2 + U_1^2 + \dots + U_k^2}$$

2.

$$U_{av} \stackrel{\text{def}}{=} \frac{1}{T} \int_0^T |i| dt$$

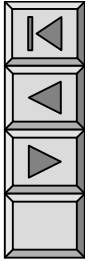
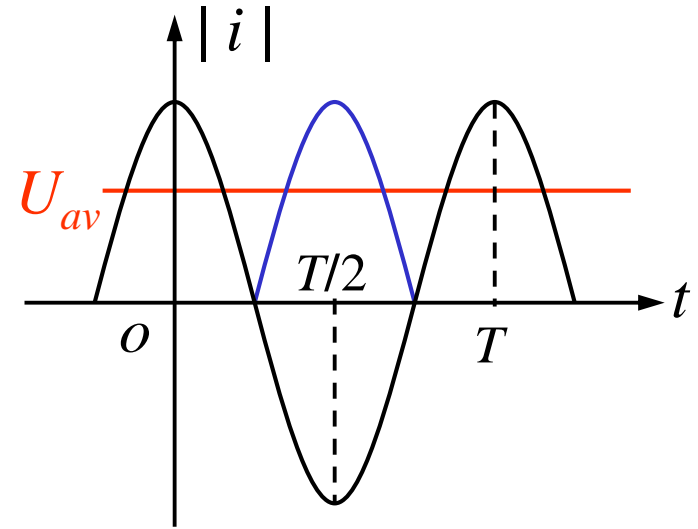

$$\left(\frac{1}{T} \int_0^T i dt \right)$$

A_0

$$\left(\frac{1}{T} \int_0^T i^2 dt \right)$$

$$\left(\frac{1}{T} \int_0^T |i| dt \right)$$

3.

$$i = I_0 + \sum_{k=1}^{\infty} I_{km} \cos(k\omega_1 t + \varphi_{ik})$$

$$u = U_0 + \sum_{k=1}^{\infty} U_{km} \cos(k\omega_1 t + \varphi_{uk})$$

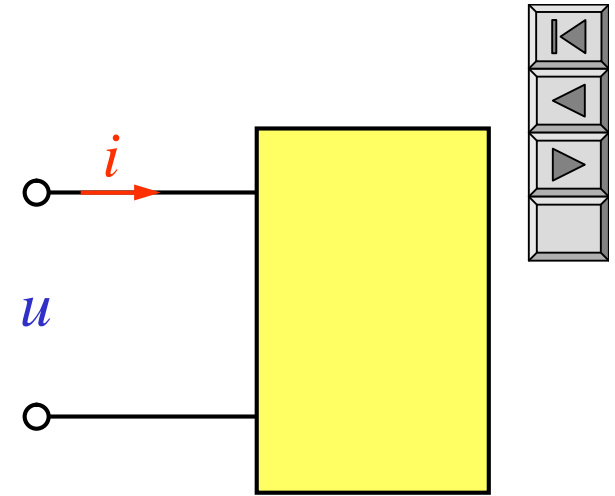

$$p = ui$$

$$P = \frac{1}{T} \int_0^T ui \, dt$$

$$P = U_0 I_0 + \sum_{k=1}^{\infty} U_k I_k \cos \varphi_k$$

$$U_k = I_k Z_k$$

$$P_k = I_k^2 R_k$$

§ 13-4

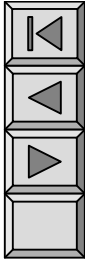

$L \quad C$

“

”

$X_{kL} \quad k \quad L$

$X_{kC} \quad \frac{1}{k \quad C}$

2

$$u_S = [10 \quad 141.40 \cos(\omega_1 t) \quad 47.13 \cos(3\omega_1 t) \quad 28.28 \cos(5\omega_1 t) \quad 20.20 \cos(7\omega_1 t) \quad 15.71 \cos(9\omega_1 t)] \text{ V},$$

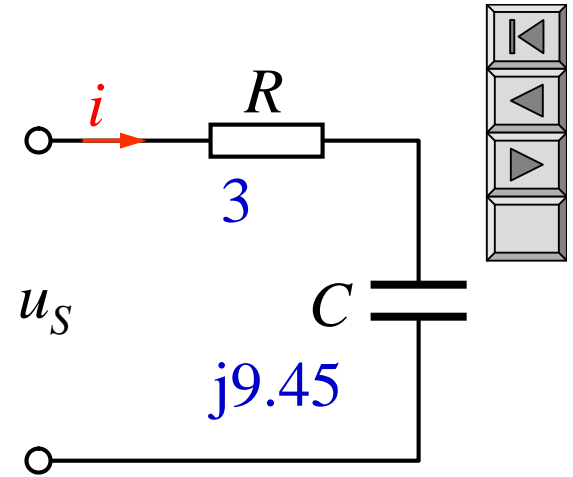

$k = 1$

$$\dot{I}_{m(1)} = \frac{141.4 \angle 0^\circ}{3 - j9.45}$$

$$14.26 \angle 72.39^\circ \text{ A}$$

$$P_{(1)} = I_{(1)}^2 R = \frac{1}{2} I_{m(1)}^2 R$$

$$305.02 \text{ W}$$

$$k = 0 \quad C$$

$$I_0 = 0 \quad P_0 = 0$$

$$\dot{I}_{m(1)} = 14.26 \angle 72.39^\circ \text{ A}, P(1) = 305.02 \text{ W}$$

$$k = 3 \quad X_{C(3)} = \frac{1}{3} X_{C(1)} = \frac{9.45}{3} = 3.15$$

$$\dot{I}_{m(3)} = \frac{47.13 \angle 0^\circ}{3 + j3.15} = 10.83 \angle 46.4^\circ \text{ A}$$

$$P_{(3)} = I_{(3)}^2 R = \frac{1}{2} I_{m(3)}^2 R = 175.93 \text{ W}$$

$$\dot{I}_{m(5)} \quad \dot{I}_{m(7)} \quad \dot{I}_{m(9)} \quad P_{(5)} \quad P_{(7)} \quad P_{(9)}$$

$$i = 14.26 \cos(\omega_1 t - 72.39^\circ) + 10.83 \cos(3\omega_1 t - 46.4^\circ)$$

$$P = P_0 + P_{(1)} + P_{(3)} + \dots + P_{(9)} = 669.8 \text{ W}$$

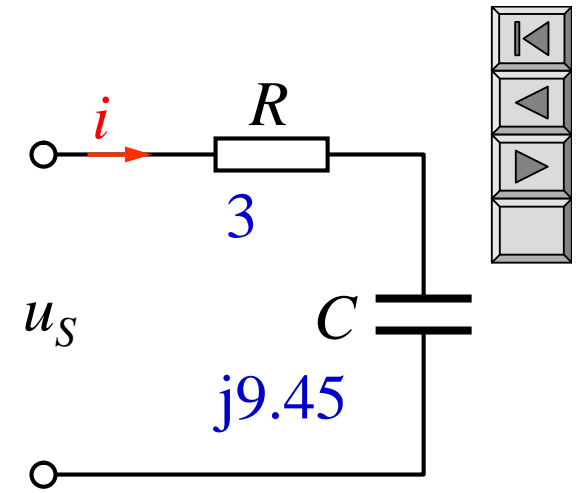

C_3
 C_2
 C_1
 L 0.1H C_3 1 F

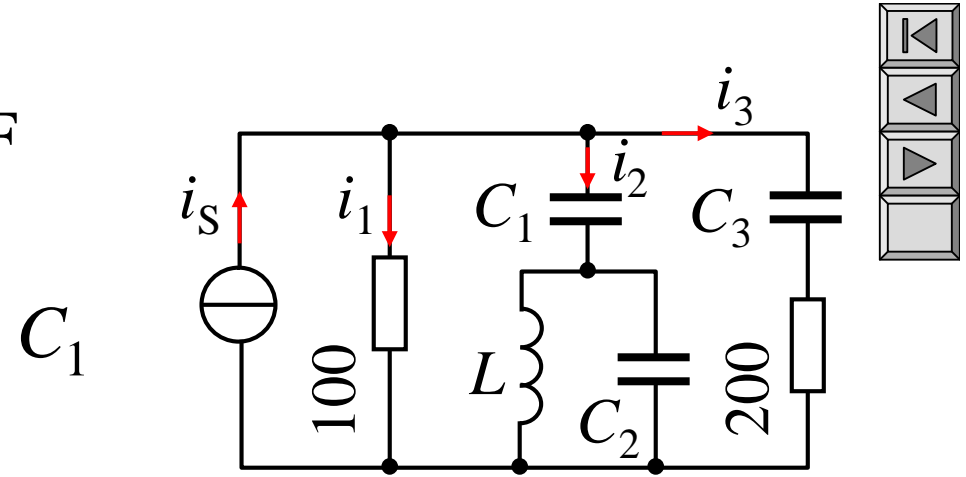

C_1
 L C_2

$C_2 = \frac{1}{L} = \frac{10}{9} \text{ F}$

C_3
 L C

i_s 5 A
 L 0.1 H
 C_1 20 μ F
 C_2 10 μ F
 C_3 1 F
 i_s 5 A
 $20\cos 1000t$ A
 $10\cos 3000t$ A

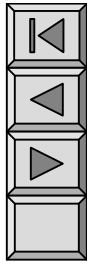
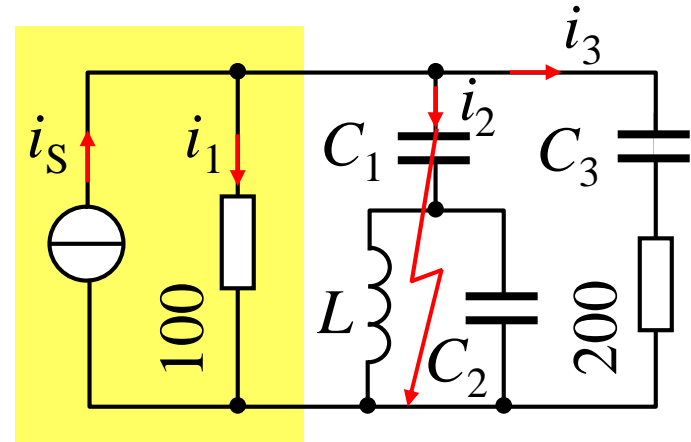

$I_{1(0)}$ 5 A
 $I_{2(0)}$ $I_{3(0)}$

$i_{2(1)}$ $20\cos 1000t$ A

$i_{1(1)}$ $i_{3(1)}$

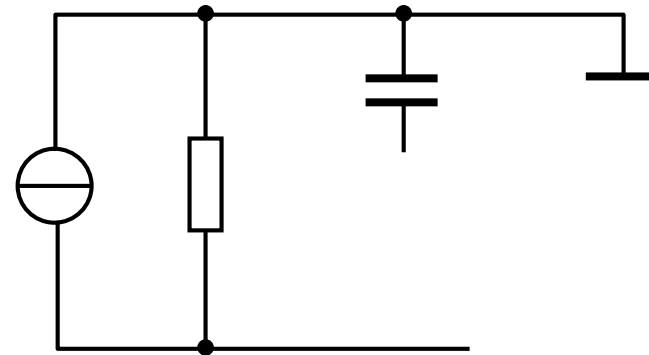

$$\begin{array}{l}
 3 \quad C1 \quad C2 \\
 L=0.1\text{H} \quad C3=1\text{mF} \\
 i_s \quad 5 \quad 20\cos 1000t \quad 10\cos 3000t \text{ A}
 \end{array}$$

$$I_{1(0)} \quad 5\text{A} \quad I_{2(0)} \quad I_{3(0)}$$

$$i_{2(1)} \quad 20\cos 1000t \text{ A}$$

$$i_{1(1)} \quad i_{3(1)}$$

$$\dot{I}_{3m(3)} \quad 2.23 \angle 48^\circ \text{ A}$$

$$\dot{I}_{1m(3)} \quad 8.67 \angle 11^\circ \text{ A}$$

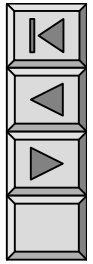
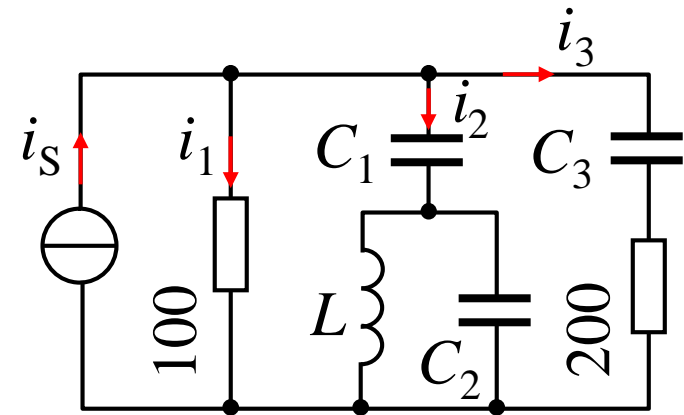

$$i_{3(3)} \quad 2.23\cos(3000t \quad 48^\circ)\text{A}$$

$$i_{1(3)} \quad 8.67\cos(3000t \quad 11^\circ)\text{A}$$

$$i_1 \quad 5 \quad 8.67\cos(3000t \quad 11^\circ)\text{A}$$

$$i_2 \quad 20\cos 1000t \text{ A}$$

$$i_3 \quad 2.23\cos(3000t \quad 48^\circ)\text{A}$$



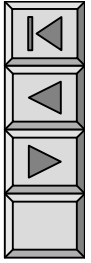

u_A

$$u_A = U_{m1} \cos(\omega_1 t) + U_{m3} \cos(3\omega_1 t) + U_{m5} \cos(5\omega_1 t) + U_{m7} \cos(7\omega_1 t)$$

u_B u_C

$$u_B = U_{m1} \cos(\omega_1 t - 120^\circ) + U_{m3} \cos(3\omega_1 t - 360^\circ) + U_{m5} \cos(5\omega_1 t - 600^\circ) + U_{m7} \cos(7\omega_1 t - 840^\circ)$$

$$u_C = U_{m1} \cos(\omega_1 t + 120^\circ) + U_{m3} \cos(3\omega_1 t + 360^\circ) + U_{m5} \cos(5\omega_1 t + 600^\circ) + U_{m7} \cos(7\omega_1 t + 840^\circ)$$



$$u_A = U_{m1} \cos(\omega_1 t) + U_{m3} \cos(3\omega_1 t) + U_{m5} \cos(5\omega_1 t) + U_{m7} \cos(7\omega_1 t)$$

$$u_B = U_{m1} \cos(\omega_1 t - 120^\circ) + U_{m3} \cos(3\omega_1 t - 120^\circ) + U_{m5} \cos(5\omega_1 t - 120^\circ) + U_{m7} \cos(7\omega_1 t - 120^\circ)$$

$$u_C = U_{m1} \cos(\omega_1 t + 120^\circ) + U_{m3} \cos(3\omega_1 t + 120^\circ) + U_{m5} \cos(5\omega_1 t + 120^\circ) + U_{m7} \cos(7\omega_1 t + 120^\circ)$$

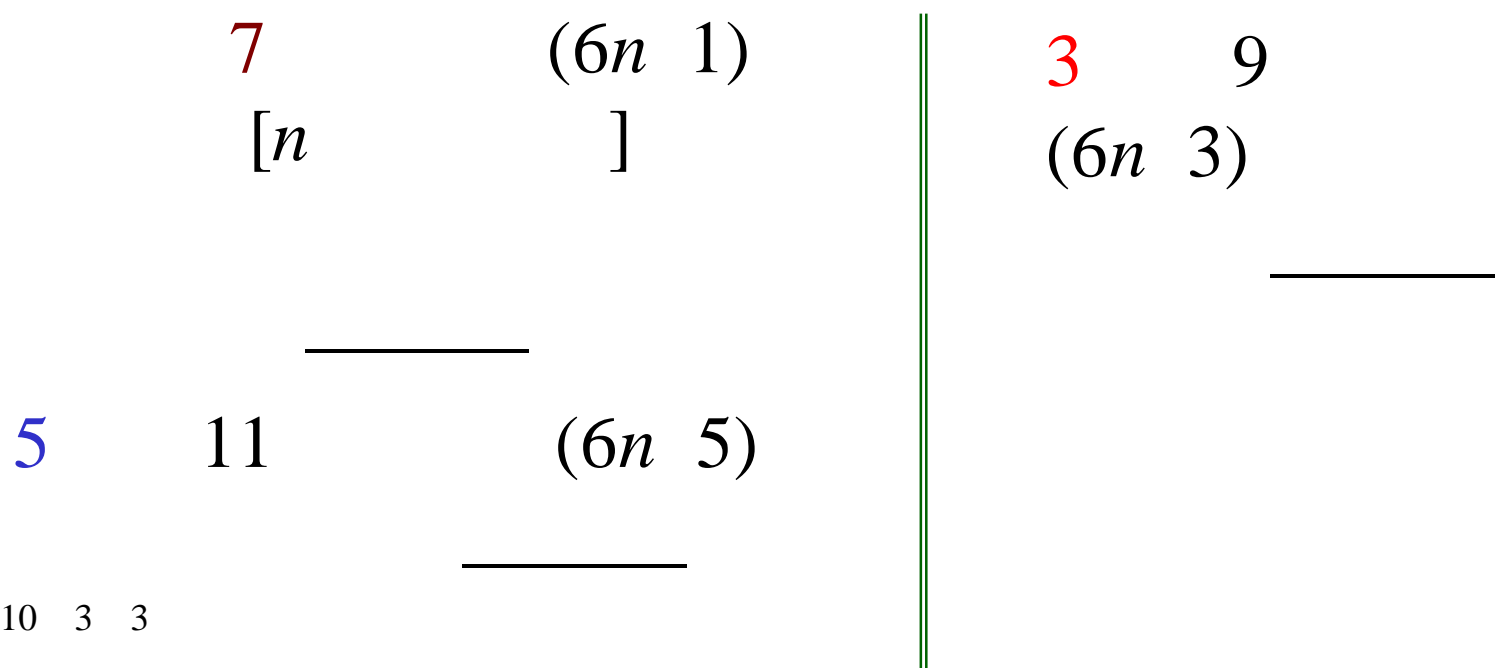

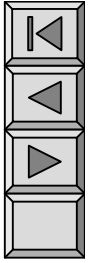

1. Y

$$U_{\text{ph}} = \sqrt{U_{\text{ph1}}^2 + U_{\text{ph3}}^2 + U_{\text{ph5}}^2}$$

(u_{AB} u_A u_B)

$$U_l = \sqrt{U_{l1}^2 + U_{l5}^2 + U_{l7}^2}$$

$$U_l = \sqrt{3} \sqrt{U_{\text{ph1}}^2 + U_{\text{ph5}}^2 + U_{\text{ph7}}^2}$$

2.

§ 11-3

()

$$U_{N'N} = \sqrt{U_{\text{ph3}}^2 + U_{\text{ph9}}^2}$$

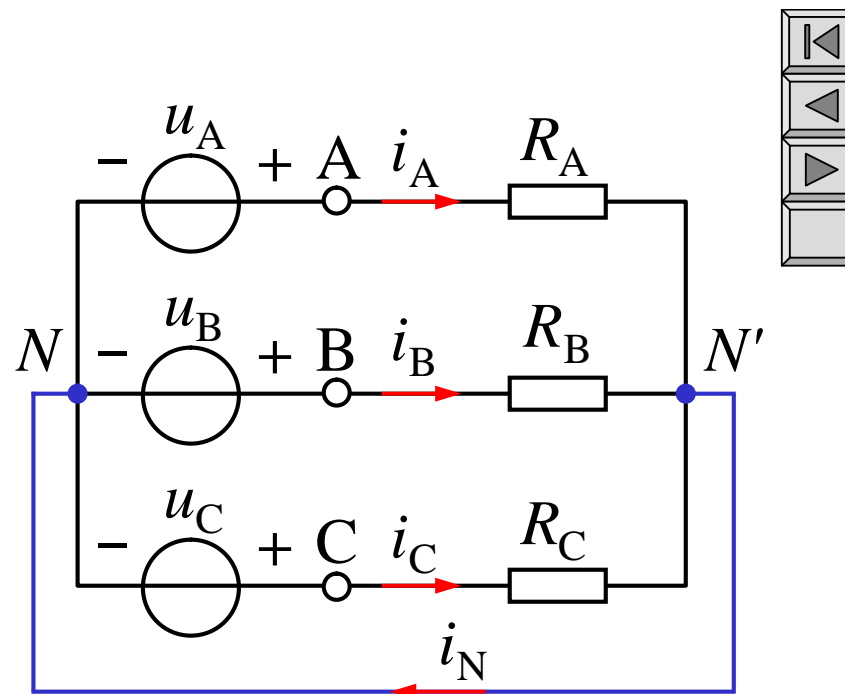

$\sqrt{3}$

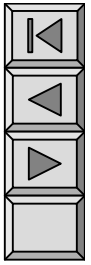

- A.
- B.
- C.

