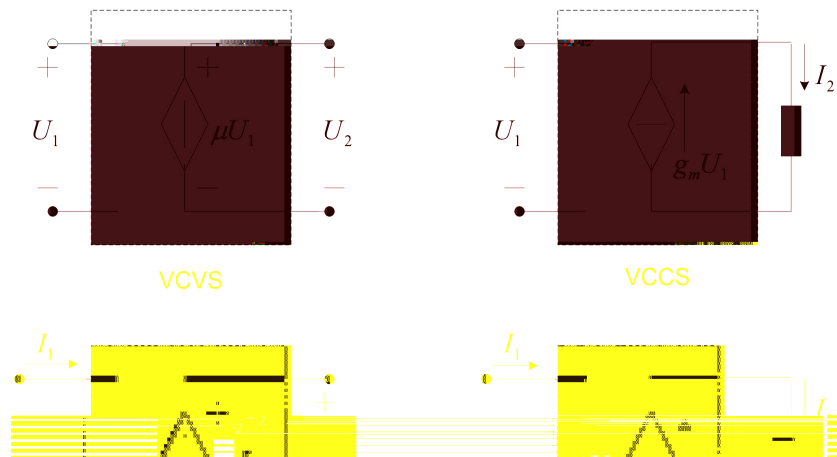

E_S I_S $U_1 \quad I_1$ $U_2 \quad I_2$ 

$$R_1 = 0 \quad U_1 = 0$$

$$G_1 = 0$$

$$I_1 = 0$$

×

$$U_2 = f(U_1) \quad \mu = U_2 / U_1$$

$$I_2 = f(U_1) \quad \mathfrak{g}_m = I_2 / U_1$$

$$U_2 = f(I_1) \quad r_m = U_2 / I_1$$

$$I_2 = f(I_1) \quad \alpha = I_2 / I_1$$

$$R_L = 2 \text{ k}\Omega$$

$$U_1$$

$$I_2$$

$$I_2 = f(U_1)$$

$$g_m$$

| | | | | | | | | | | |
|----------|--|--|--|--|--|--|--|--|--|--|
| U_1 V | | | | | | | | | | |
| I_2 mA | | | | | | | | | | |

$$U_1 = 5 \text{ V}$$

$$R_L$$

$$U_2 \quad I_2$$

$$I_2 = f(U_2)$$

| | | | | | | | | | |
|----------------|--|--|--|--|--|--|--|--|--|
| R_L Ω | | | | | | | | | |
| U_2 V | | | | | | | | | |
| I_2 mA | | | | | | | | | |

$$U_2 = f(I_1)$$

$$U_2 = f(I_2)$$

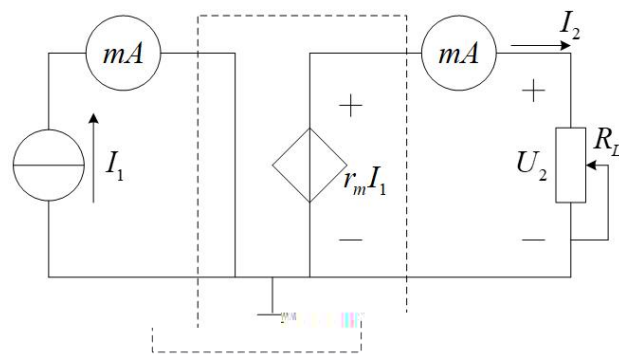

$$R_L = 2 \text{ k}\Omega$$

$$I_1$$

$$I_1$$

$$I_1 = 0.4 \text{ mA}$$

 R_L $U_2 \quad I_2$

$$U_2 = f(I_2)$$

| | | | | | | | |
|-----------------------|--|--|--|--|--|--|--|
| $R_L \text{ k}\Omega$ | | | | | | | |
| $U_2 \text{ V}$ | | | | | | | |
| $I_2 \text{ mA}$ | | | | | | | |

$$I_1 = I'_1 - I''_1 \quad I_2 = -I'_2 + I''_2 \quad I_3 = I'_3 + I''_3 \quad U = U' + U''$$

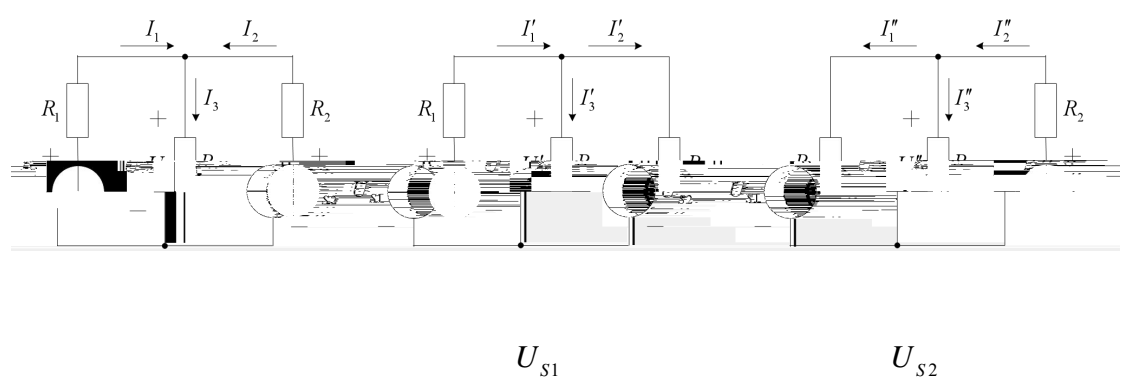

$$R_1 = R_3 = R_4 = 510 \Omega \quad R_2 = 1 \text{ k}\Omega \quad U_{S1} = 12 \text{ V}$$

$$U_{S2} = 6 \text{ V}$$

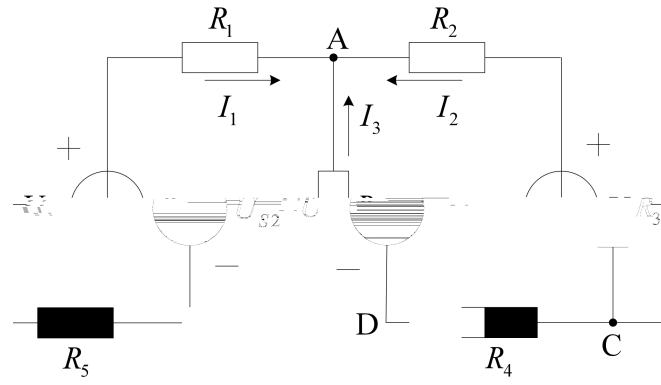

$$U_{S1} \quad U_{S2}$$

| | U_{S1} | U_{S2} | I_1 | I_2 | I_3 | U_{BC} | U_{AC} | U_{CD} |
|----------|----------|----------|-------|-------|-------|----------|----------|----------|
| | | | | | | | | |
| U_{S1} | | | | | | | | |
| U_{S2} | | | | | | | | |
| U_{S2} | | | | | | | | |

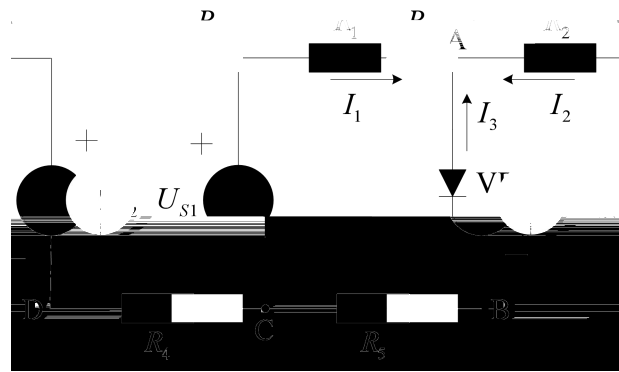
U_{S1} U_{S2} U_{S2} U_{S2} U_{S1} U_{S1} R_3 

| | U_{S1} | U_{S2} | I_1 | I_2 | I_3 | U_{BC} | U_{AC} | U_{CD} |
|----------|----------|----------|-------|-------|-------|----------|----------|----------|
| | | | | | | | | |
| U_{S1} | | | | | | | | |
| U_{S2} | | | | | | | | |
| U_{S2} | | | | | | | | |

U_{oc}

R_o

I_{sc}

R_o

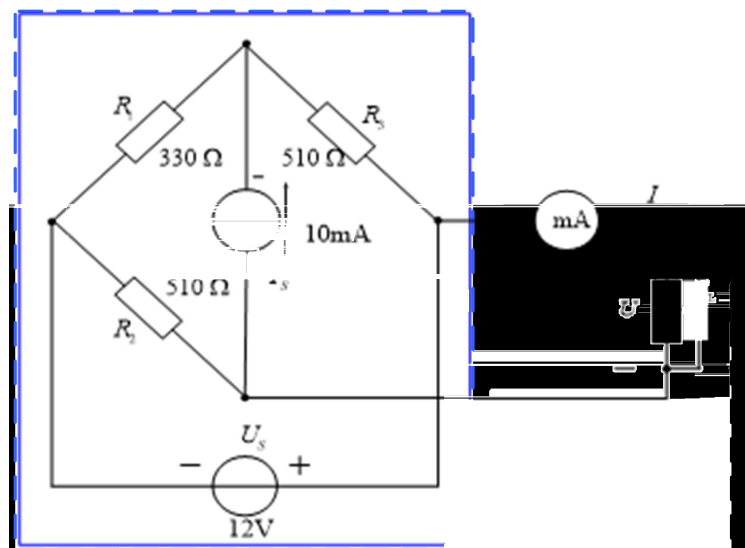

R_L

U I

$R_L = 0$

$I_{SC} \quad R_L = \infty$

U_{oc}

| | | | | | | | | | |
|----------------|--|--|--|--|--|--|--|--|----------|
| $R_L (\Omega)$ | | | | | | | | | ∞ |
| $U (V)$ | | | | | | | | | |
| $I (mA)$ | | | | | | | | | |

R_o

R_o

U_{oc}

I_{sc}

$R_o = U_{oc} / I_{sc}$

U_{oc}

R_o

R_L

U

I

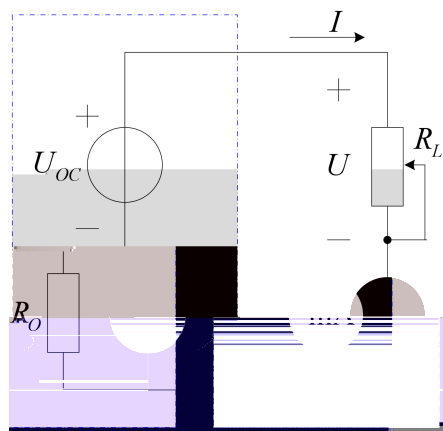

| | | | | | | | | | |
|----------------|--|--|--|--|--|--|--|--|----------|
| $R_L (\Omega)$ | | | | | | | | | ∞ |
| $U (V)$ | | | | | | | | | |
| $I (mA)$ | | | | | | | | | |

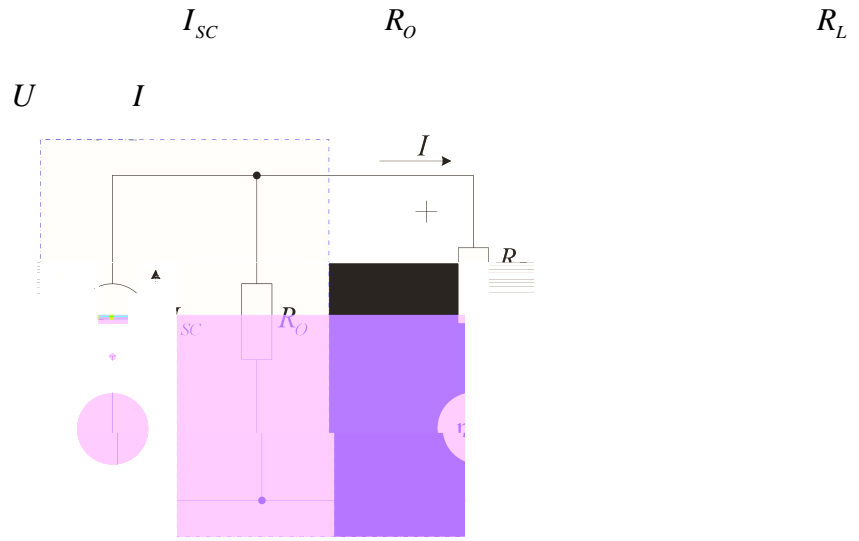

| | | | | | | | | | |
|----------------|--|--|--|--|--|--|--|--|----------|
| $R_L (\Omega)$ | | | | | | | | | ∞ |
| $U (V)$ | | | | | | | | | |
| $I (mA)$ | | | | | | | | | |

U I

R_o

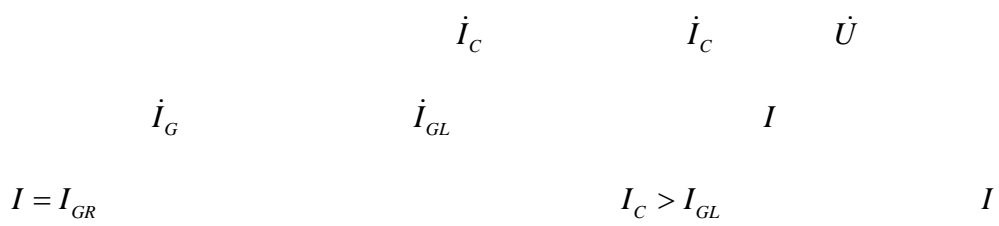
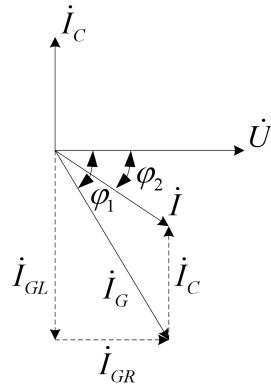
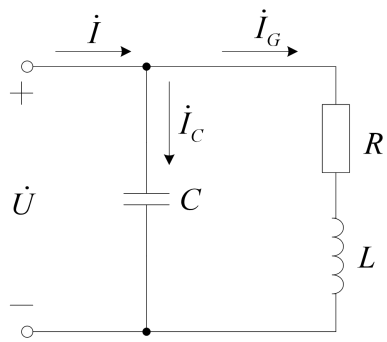

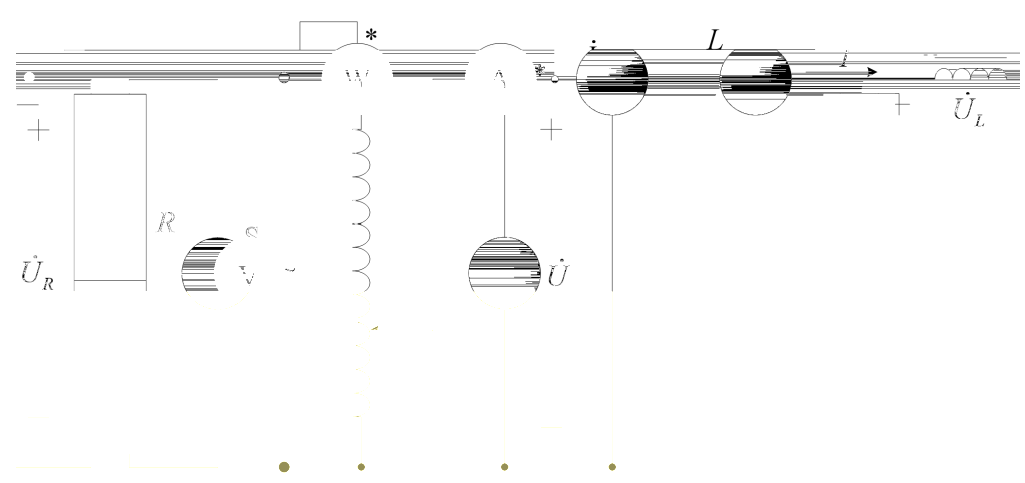
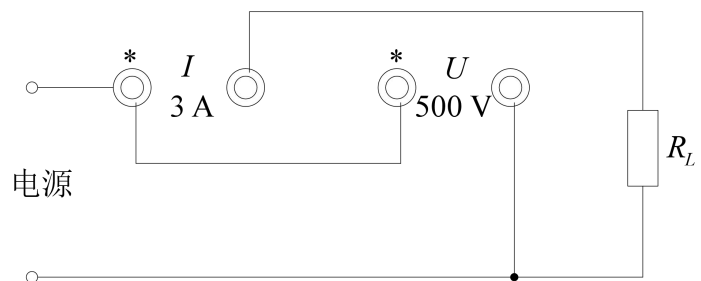

$U \quad U_L \quad U_R \quad I \quad P$

| | $U \text{ V}$ | U_L | U_R | I | $P \text{ W}$ | $\cos \varphi$ |
|--|---------------|-------|-------|-----|---------------|----------------|
| | | | | | | |
| | | | | | | |

$U \quad U_L \quad U_R \quad I \quad P$

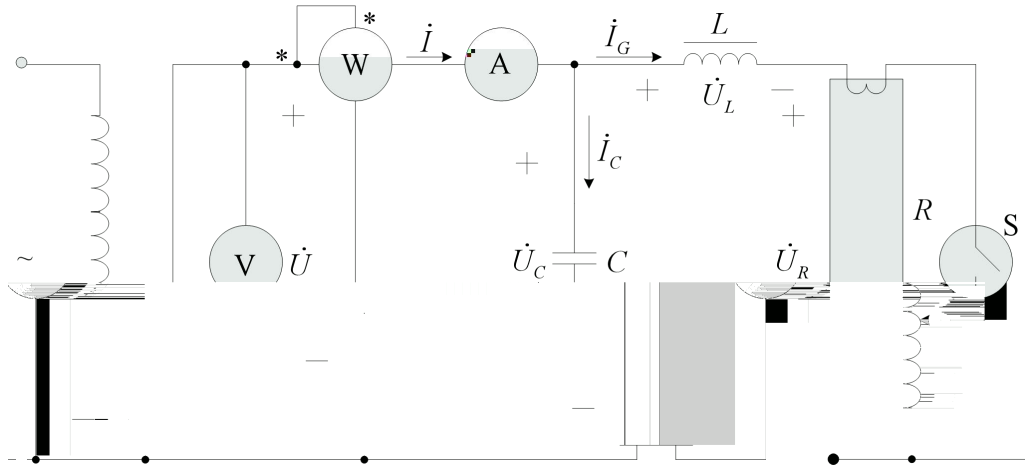

$U \quad U_C \quad U_L \quad U_R \quad I \quad I_G \quad I_C \quad P$

| $C \text{ } \mu\text{F}$ | $U \text{ V}$ | U_C | U_L | U_R | I | I_G | I_C | $P \text{ W}$ | $\cos \varphi$ |
|--------------------------|---------------|-------|-------|-------|-----|-------|-------|---------------|----------------|
| | | | | | | | | | |
| | | | | | | | | | |
| | | | | | | | | | |
| | | | | | | | | | |

$$I = f(C)$$

$$\cos \varphi = f(C)$$

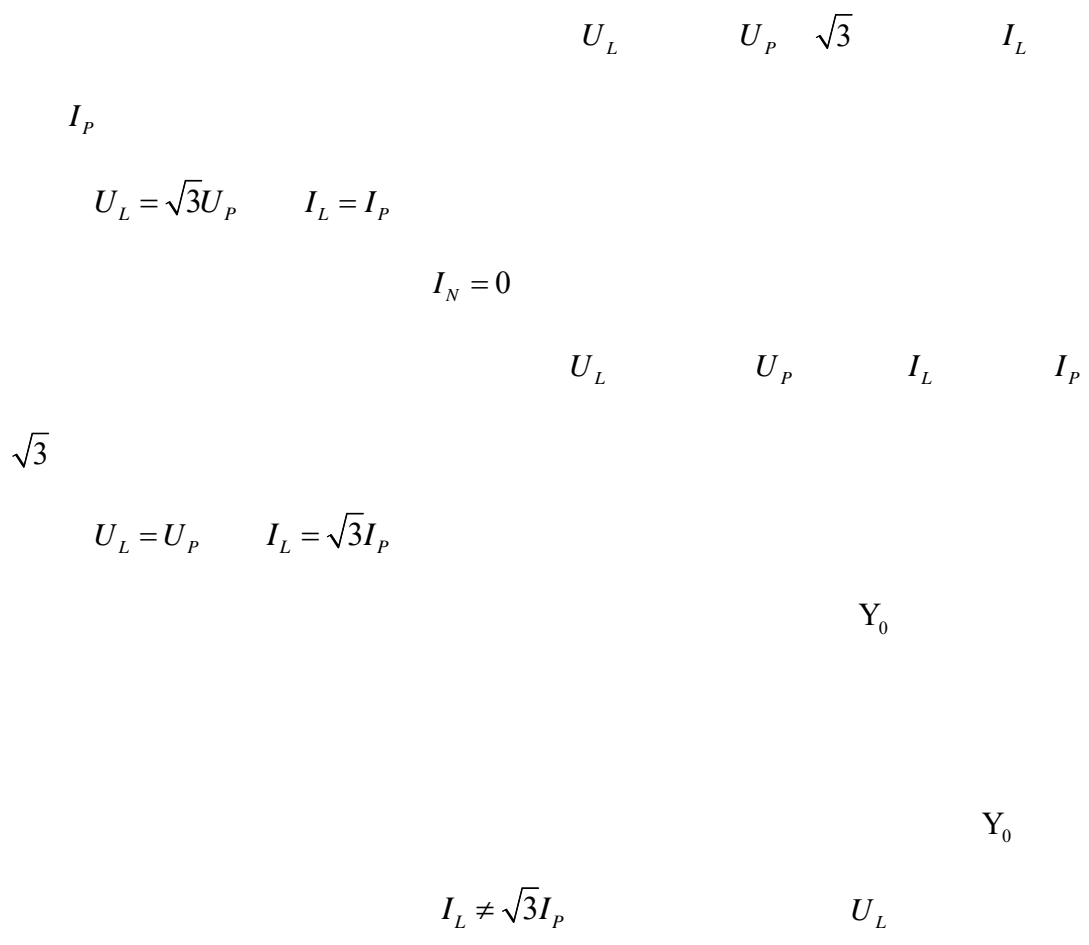

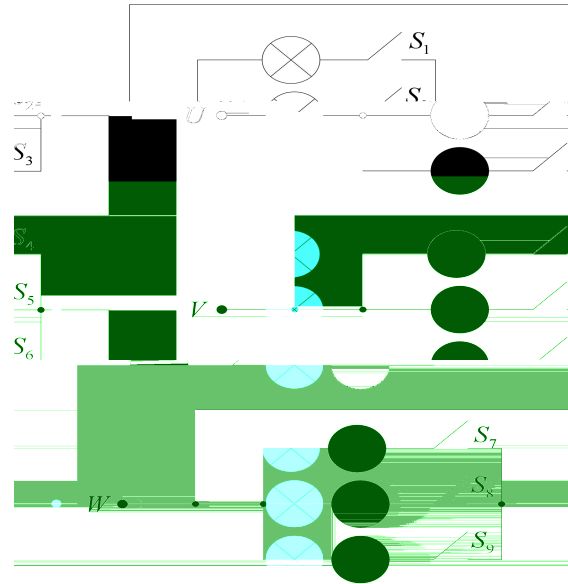

| | U_{AB} | U_{BC} | U_{CA} | I_{AB} | I_{BC} | I_{CA} | I_A | I_B | I_C | $\frac{I_A}{I_{AB}}$ | $\frac{I_B}{I_{BC}}$ | $\frac{I_C}{I_{CA}}$ |
|--|----------|----------|----------|----------|----------|----------|-------|-------|-------|----------------------|----------------------|----------------------|
| | | | | | | | | | | | | |
| | | | | | | | | | | | | |

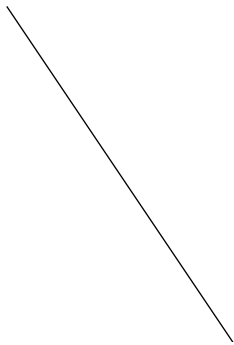
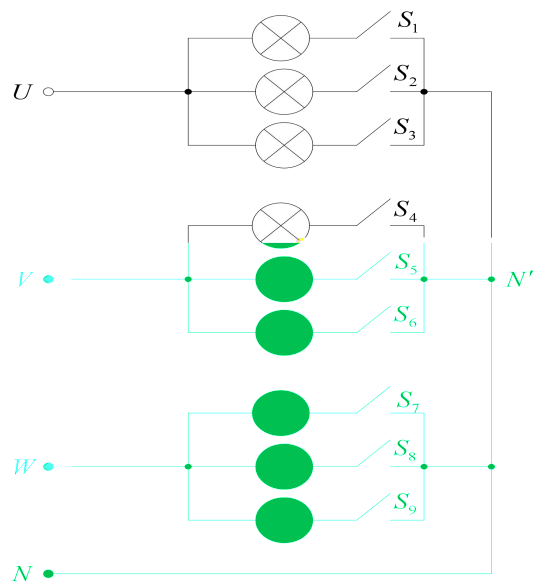

U_{AB} U_{BC} U_{CA} U_A U_B U_C I_A I_B

$$\sqrt{3}$$

